

2020
PRODUCTS



Product Catalogue

Smoke Motorized Damper



Khedr Trust
ALL AIR PRODUCTS

Smoke Motorized Damper products are
manufactured by



“Your comfort is
our priority”



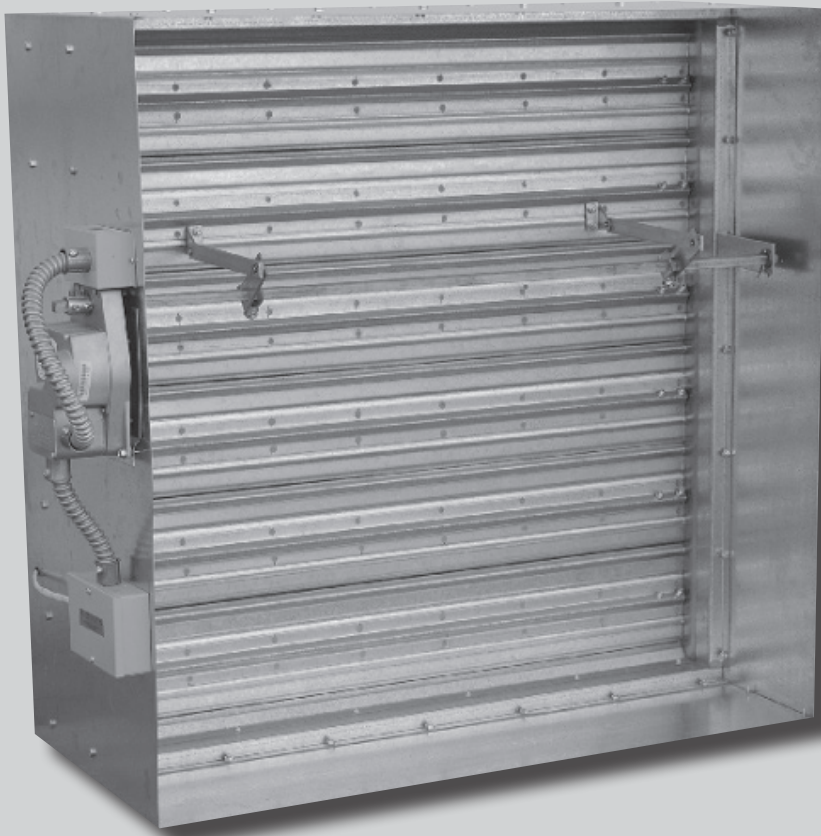

Models

- SMD-S "Smoke Motorized Damper"
- SMD-C "Combination Fire / Smoke motorized Damper"



Features

- 5" X 16 G galvanized hat shaped steel channel.
- 16 Ga Galvanized Steel Blades reinforced with longitudinal vees.
- UL Listed Fusible Link " 165 F Fusing Temperature " for SMD-C only.
- All Dampers are Fire rated for 1 1/2 hour.
- Spring Return Actuator.

Smoke Motorized Damper

Model Design

Khedr Model SD Smoke Damper are designed to prevent the passage of Smoke form one side of fire rated separation to the other.

NFPA 90

Khedr Model SD meets the latest requirements of NFPA 90.

Model Types

Khedr Models SD are suitable to use in vertical or Horizontal installation.

- Construction & Specs.

- Type (SMD-S) - Smoke Motorized Damper

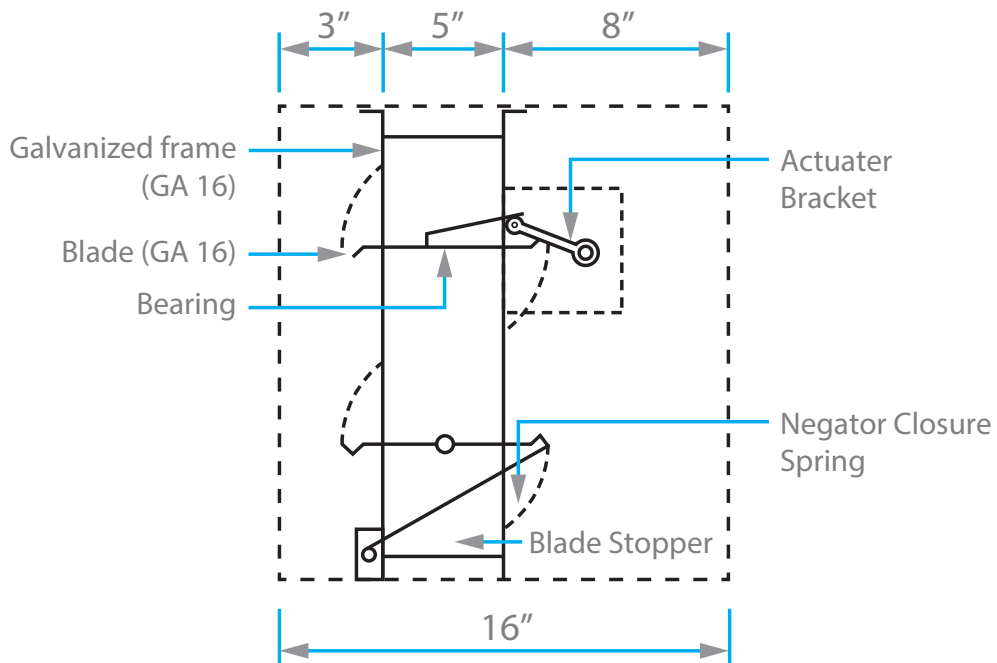
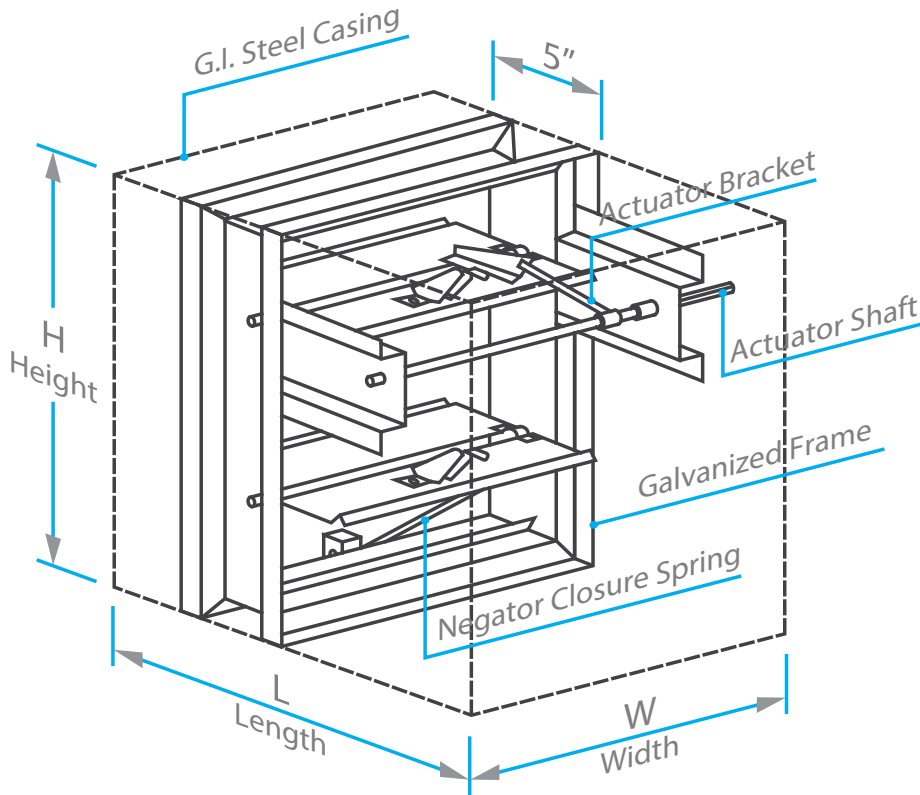

- Type (SD-C) - Combination Fire / Smoke Motorized Damper

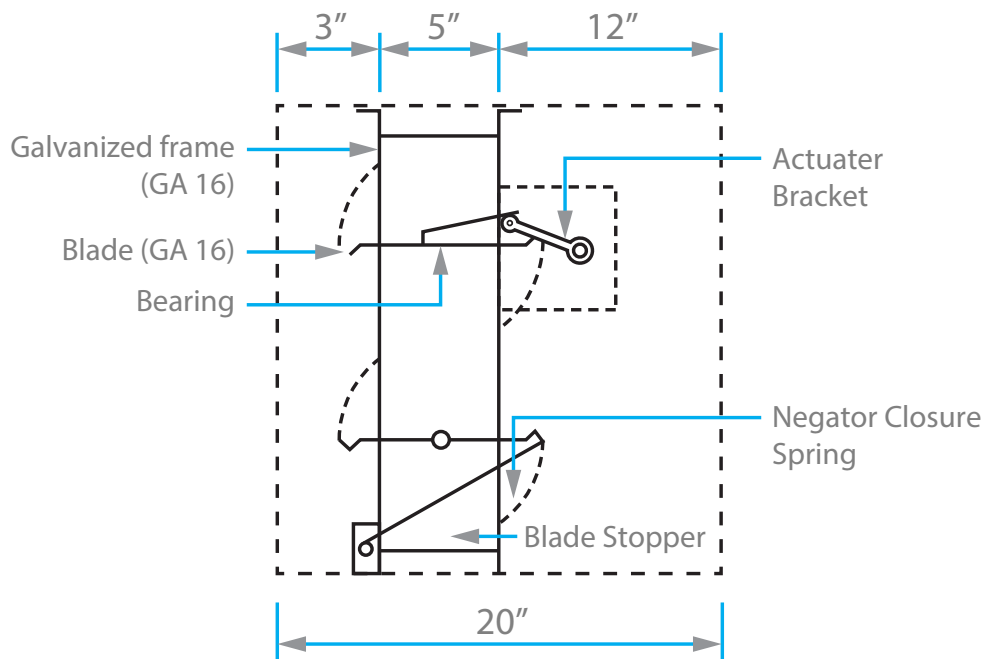
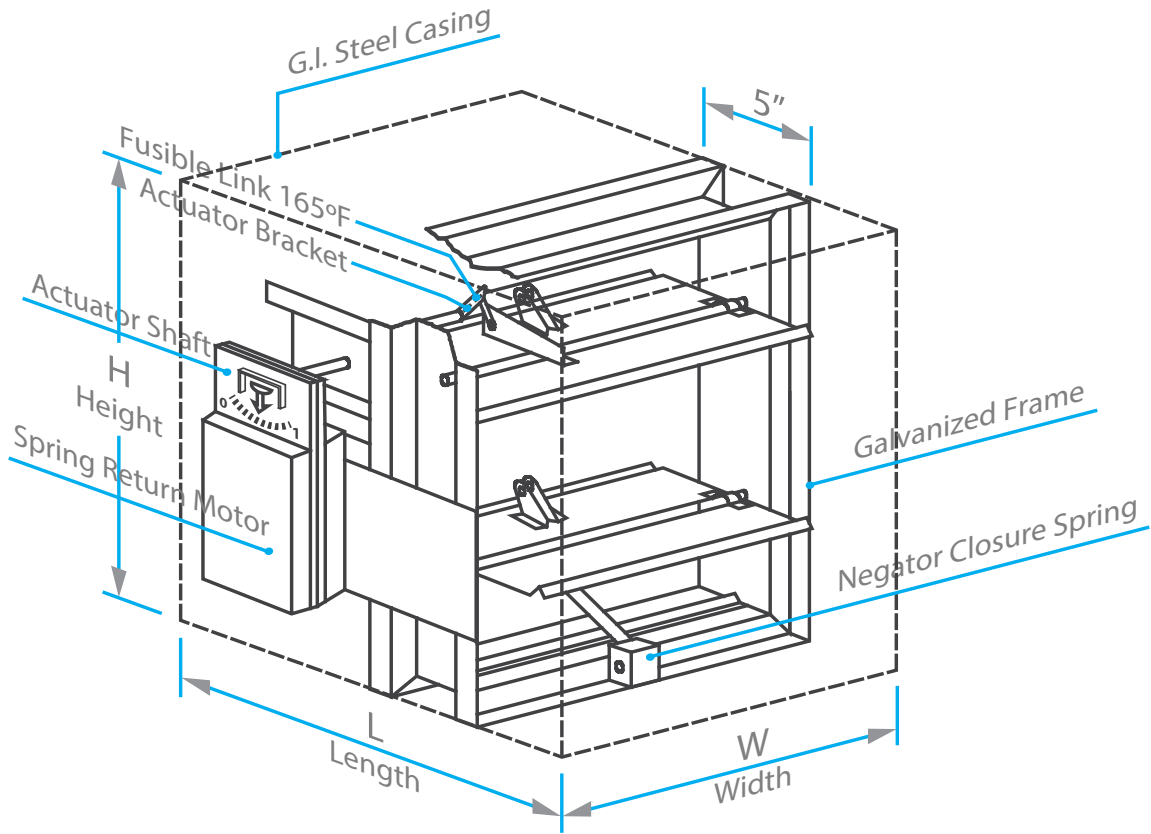

- Aerodynamic Data

1. Pressure Drop Chart *

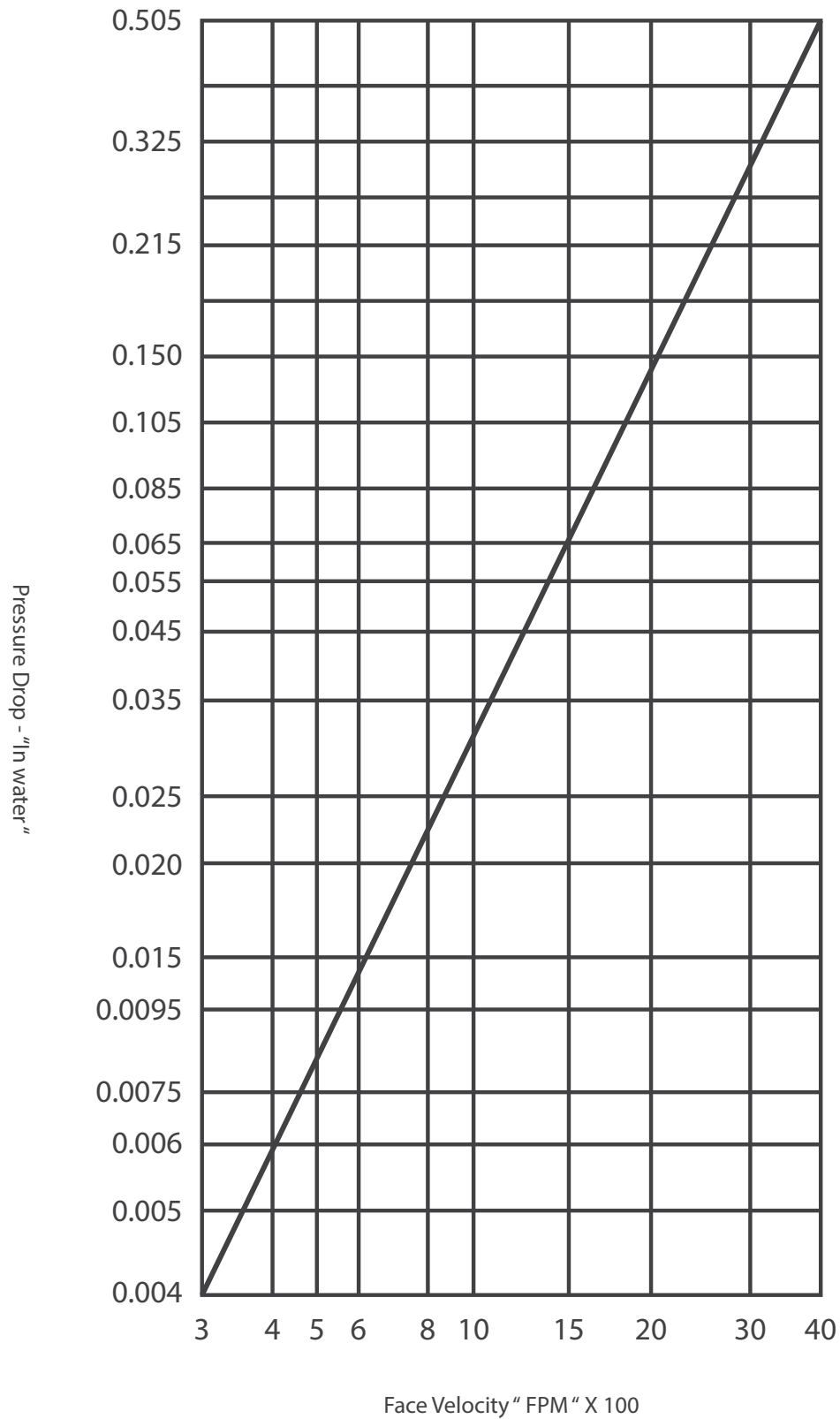

* Damper in Full Open Position

2. Leakage Chart

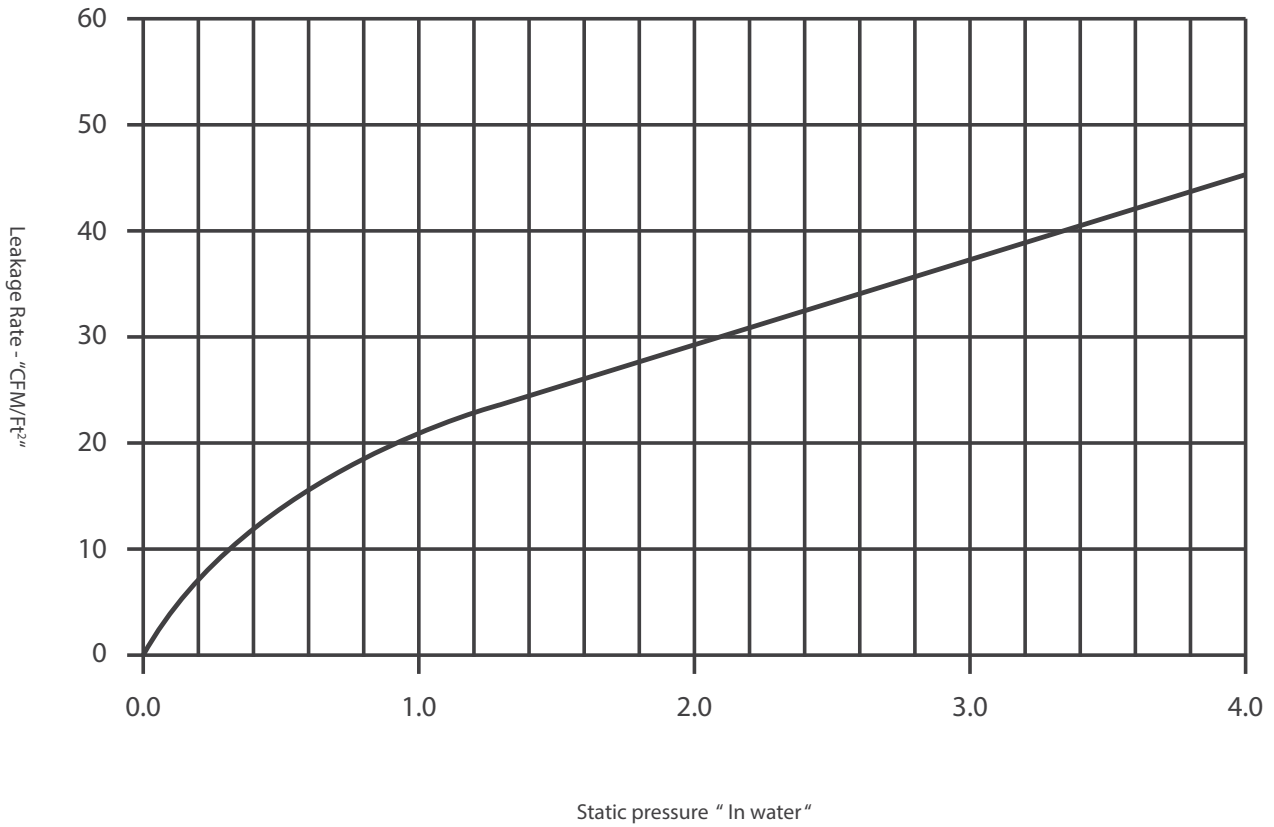

- How to order

Type	FD-A	SMD-S "Smoke Motorized Damper" SMD-C "Combination Fire / Smoke Motorized Damper"	Smoke Motorized Damper products are manufactured by Khedr Trust Co.
Size	24 x 24	Size "Inch"	
Frame	0	O Standard S Sleeve F Frame	

Other Products are provided by Khedr Trust Co.

Diffusers & Grills

- Square Ceiling Diffuser
- Circular Ceiling Diffuser
- Smoke Motorized Damper
- Eye Ball Diffuser
- Swirl Diffuser
- Perforated Ceiling Diffuser
- Disc Valve Diffuser
- Linear Slot Diffuser
- SSmoke
- Supply / Return Grills

Louvers

- Aluminum Louvers
- Sand Trap Louvers

Dampers

- Volume Damper
- Smoke Motorized Damper
- Fire Damper
- Shutter Damper

Special Parts

- Sound Attenuator
- Plenum Box

Duct Works

- Galvanized Steel Duct
- Black Steel Duct
- Stainless Steel Duct
- Spiral Duct
- Flexible Duct
- Canvas
- Flanges



Khedr Trust

ALL AIR PRODUCTS



Alqanater Alkhairia roads.Industrial Area, Behind Cocacola Co., Cairo, Egypt

Mailing Address : P.O.Box 13621, Cairo 11511 - Egypt

Tel : +202 42452022

Mob : +2010 29999054 / +2010 29999056

+2010 29999057 / +2010 29999058

E-Mail : info@khedr-eg.com

www.khedr-eg.com

